

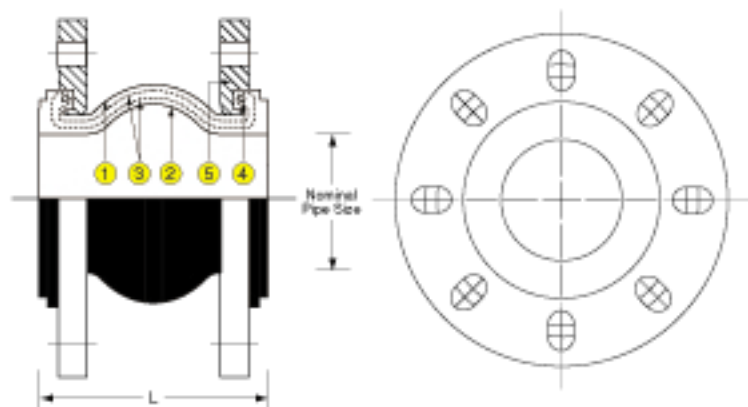

# STYLE 99 SF - UNIVERSAL TYPE

## SINGLE SPHERE UNIVERSAL DUCTILE IRON FLANGE



S/NO	PART NAME	MATERIAL
1	Body (Outer Layer)	Special Synthetic Rubber
2	Body (Inner Layer)	Special Synthetic Rubber
3	Reinforcing Fabric	Nylon Fabric
4	Wire	Hard Steel Wire
5	Flange	Ductile Iron with Epoxy Coated

Operating Pressure : 16 Bar  
 Operating Temperature : -10 to 80 Deg C  
 Vacuum Rating : 700 MMHG  
 \*Applicable Fluids : Water, Warm Water, Sea Water, Air & Weak Acid  
 Universal Flanges Standard : PN10/16, ANSI 150# & JIS 10K

NOMINAL PIPE SIZE		NEUTRAL LENGTH L	AXIAL COMPRESSION	AXIAL ELONGATION	LATERAL DEFLECTION	ANGULAR DEFLECTION
MM	INS	MM	MM	MM	+ OR - MM	+ OR - DEG
20	3/4	93	8	4	8	15
25	1	93	8	4	8	15
32	1 1/4	93	8	4	8	15
40	1 1/2	93	8	4	8	15
50	2	99	8	4	8	15
65	2 1/2	108	12	6	10	15
80	3	116	12	6	10	15
100	4	129	12	10	12	15
125	5	142	16	10	12	15
150	6	156	16	10	12	15
200	8	177	20	14	18	15
250	10	206	20	14	18	15
300	12	217	20	14	18	15

### OPERATING TEMPERATURE AGAINST OPERATING PRESSURE

OPERATING TEMPERATURE °C	AMBIENT	50	60	70	80
MAXIMUM OPERATING PRESSURE (BAR)	16	12.4	10	7.5	6.5



### NOTES

- Higher temperatures affect movement and pressure. As temperature increases, rated values must be reduced accordingly.
- Pressures shown are recommended "operating", test pressure is 1.5 times "operating".
- Vacuum rating is based on neutral installed length without external load. Products shall not be installed "elongated" on vacuum applications.
- Expansion joints may operate in pipelines or equipments carrying fluids at evaluated temperatures and pressures. Normal precautions shall be taken to make sure these parts are installed correctly and inspected regularly. Precautions shall be taken to protect personnel in the event of leakage or splash.
- For other kinds of applicable fluids, except the above, to which the rubber joint becomes applicable, please kindly consult your supplier or manufacturer.

